

iMAX
INVERTER POOL HEAT PUMP
COMMERCIAL LINE MICROWELL



USER MANUAL

Table of contents

A. Foreword	1
B. Safety Precautions	2
1. Warning	2
2. Attention	2
3. Safety	2
C. About your heat pump	3
1. Transportation	3
2. Accessories:	3
3. Features	Error! Bookmark not defined.
4. Operating condition and range:	3
5. Introduction of different modes:	4
6. Technical parameter	4
7. Dimension	5
D. Installation guidance	6
1. Installation reminder	6
2. Wiring	8
3. Electric wiring Diagram	9
4. References for protecting devices and cable specification	9
E. Operation guidance	9
1. Key Function	10
2. Operation Instruction	10
F. Testing	11
1. Inspect heat pump before use	11
2. Trial	12
G. Maintenance	12
H. Trouble shooting for common faults	13
I. Electrical wiring schematic (optional)	15
J. Wi-Fi operation	17

A. Foreword

Thank you for choosing our inverter pool heat pump, which is designed for more silent and energy saving user experience. It is an ideal way for green pool heating.

We hope you'll enjoy using our heat pumps.

Thank you!

B. Safety Precautions

We have provided important safety messages in this manual and on your heater. Please always read and obey all safety messages.

1. Warning



The WARNING sign denotes a hazard. It calls attention to a procedure, practice, or the like, which, if not correctly performed or adhered to, could result in personal injury or injury to a third party. These signs are rare, but are extremely important.

2. Attention

- a. Set proper temperature in order to get comfortable water temperature to avoid overheating or overcooling.
- b. Please don't stack substances, which will block air flow near inlet or outlet area, otherwise the efficiency of the heater will be reduced or even stopped.
- c. Don't use or stock combustible gas or liquid such as thinners, paint and fuel to avoid fire.
- d. In order to optimize the heating effect, please install heat preservation insulation on pipes between swimming pool and the heater, and please use a recommended cover on the swimming pool.
- e. Connecting pipes of the swimming pool and the heater should be $\leq 10\text{m}$.

3. Safety

- a. Please keep the main power supply switch far away from the children.
- b. When a power cut happens during operating, and later the power is restored, the heater will start up.
- c. Please switch off the main power supply in lightening and storm weather to prevent from machine damage that caused by lightning.
- d. Installation and any repairing should be conducted in the area with good ventilation. The ignition source is prohibited during the operation.

C. About your heat pump

1. Transportation

a. Always keep upright

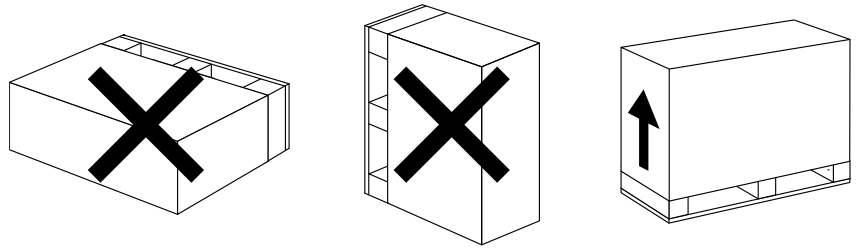

b. Loose the screws in the bottom, and use the forklift to transport.

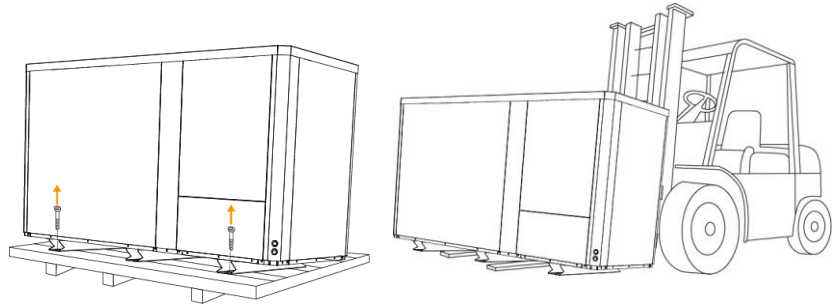

c. Do not lift the water union, otherwise, the titanium heat exchanger inside the heat pump may be damaged)

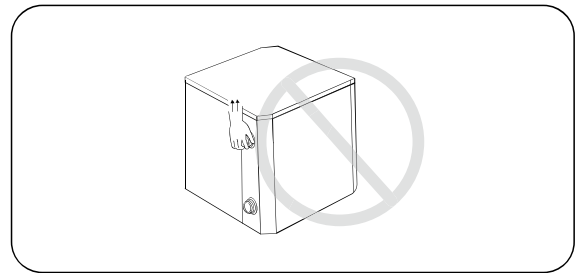

2. Accessories:

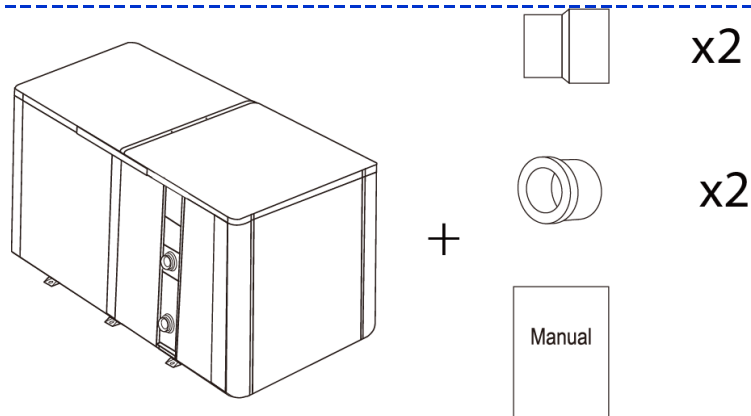



3. Operating condition and range:

To provide you comfort and pleasure, please set swimming pool water temperature efficiently and economically.

The heat pump can work between air $-10^{\circ}\text{C} \sim 43^{\circ}\text{C}$, and its ideal operation range is between air $15^{\circ}\text{C} \sim 25^{\circ}\text{C}$.

4. Introduction of different modes:

- a. The heat pump has two modes: Boost and Silence.
- b. They have different strengths under different conditions.

Mode	Modes	Strength
	Boost mode	Heating capacity: 20% to 100% capacity Intelligent optimization Fast heating
	Silence mode	Heating capacity: 20% to 80% capacity Sound level: 3dB (A) lower than Boost mode

5. Technical parameter

Model	IM60	IM110
PERFORMANCE CONDITION: Air 27°C/ Water 27°C/ Humid. 80%		
Heating capacity (kW)	60.2	115.0
Average COP at 50% Speed	10.5	10
PERFORMANCE CONDITION: Air 15°C/ Water 26°C/ Humid. 70%		
Heating capacity (kW)	40.1	80.8
Average COP at 50% Speed	7	7
TECHNICAL SPECIFICATIONS		
Advised pool volume (m ³) *	125~260	250~520
Operating air temperature (°C)	-10°C~43°C	
Fan direction	Vertical	
Power supply	400V/3Ph/50Hz	
Rated input power (kW)	2.26~8.90	4.68~17.5
Rated input current (A)	3.27~12.9	6.78~25.3
Max input current (A)	20	40
Circuit breaker (A)	25	48
Sound level at 10m dB(A)	33.0~41.0	35.0~44.0
Advised water flux (m ³ /h)	20~25	40~50
Water connection (mm)	75	110
Net dimension LxWxH (mm)	1000x1110x1260	2100x1090x1280
Net Weight (kg)	212	459

Remarks:

This heat pump is able to perform normal within air temp -10°C~43°C, efficiency will not be guaranteed out of this range. Please take into consideration that the pool heater performance and parameters are different under various conditions.

Related parameters are subject to adjustment periodically for technical improvement without further notice. For details please refer to nameplate.

6. Dimension

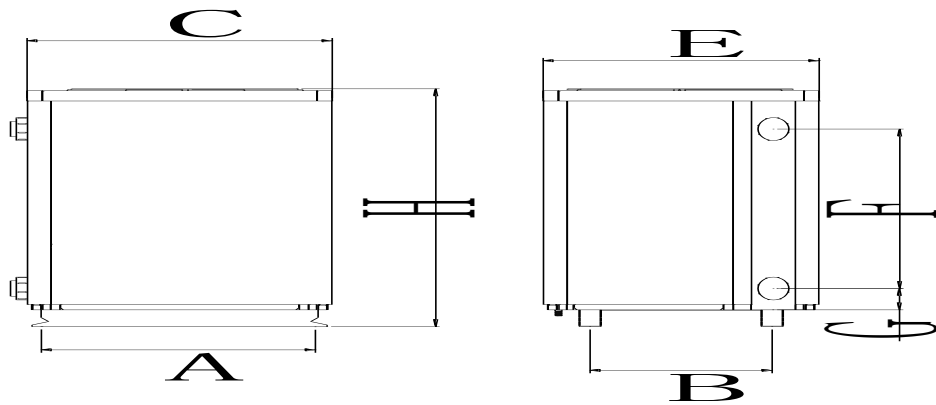

Size (mm) Name	A	B	C	D	E	F	G	H
Model								
IM60	1000	660	1110	1070	1000	780	105	1260

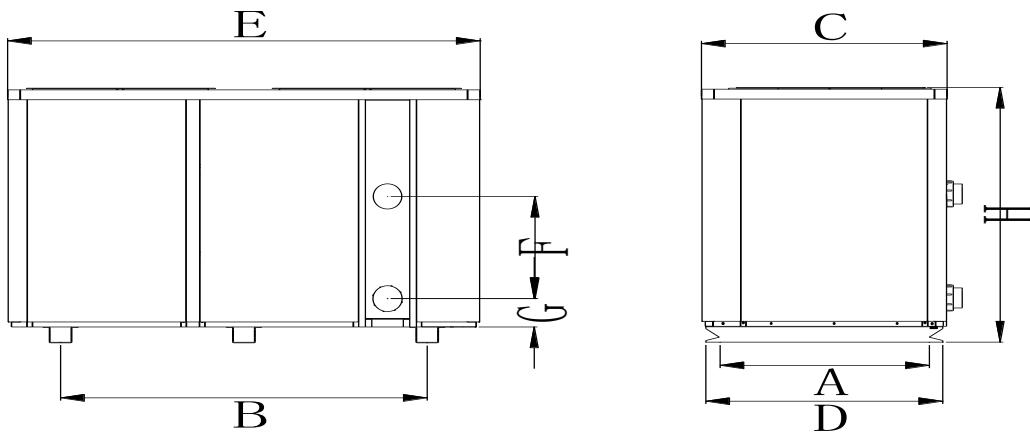

Size (mm) Name	A	B	C	D	E	F	G	H
Model								
IM110	1000	1630	1090	1050	2100	515	140	1280

D. Installation guidance

1. Installation reminder

Only a professional staff is allowed to install the heat pump. The users are not qualified to install by themselves, otherwise the heat pump might be damaged and risky for users' safety.

a. Location and water pipe connection

 The inverter pool heat pump should be installed in a good ventilation place.

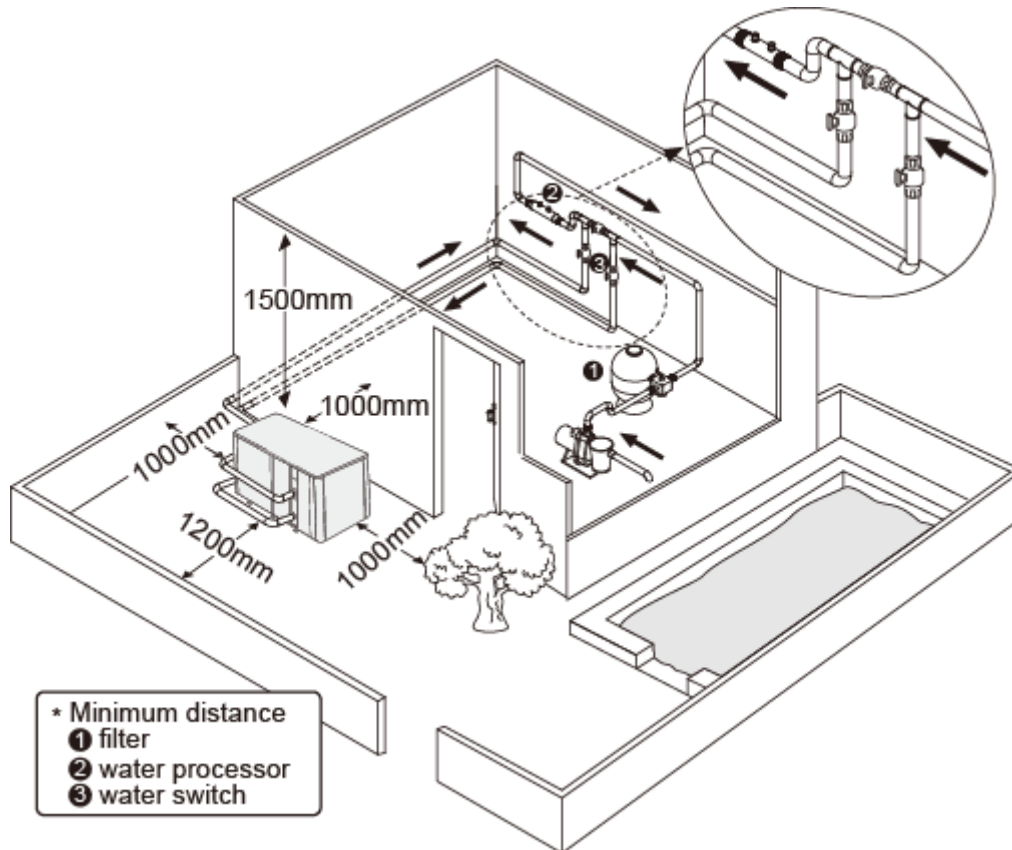

- 1) The frame must be fixed by bolts (M10) to concrete foundation or brackets. The concrete foundation must be solid and fastened; the bracket must be strong enough and antirust treated;
- 2) Please don't stack substances that will block air flow near inlet or outlet area, and there is no barrier within 50cm behind the main machine, or the efficiency of the heater will be reduced or even stopped;
- 3) The machine needs an appended pump (Supplied by the user). The recommended pump specification-flux: refer to Technical Parameter, Max. lift $\geq 10\text{m}$;
- 4) When the machine is running, there will be condensation water discharged from the bottom, please pay attention to it. Please hold the drainage nozzle (accessory) into the hole and clip it well, and then connect a pipe to drain the condensation water out.

- b. The inlet and outlet water unions can't stand the weight of soft pipes. The heat pump must be connected with hard pipes!

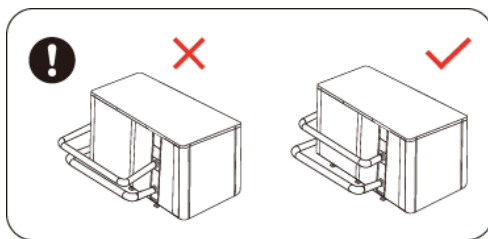

⚠ 1. How to connect to the terminal board of IM60

Step 1. open the maintenance panel

① Remove three screws outside

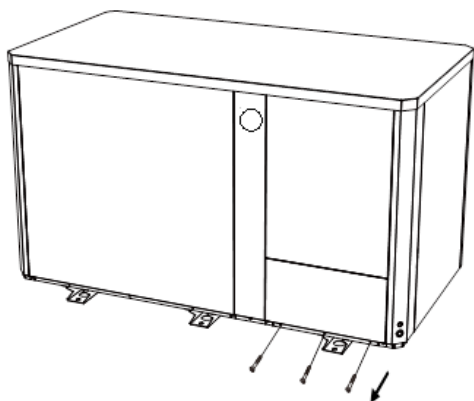

② Open the panel

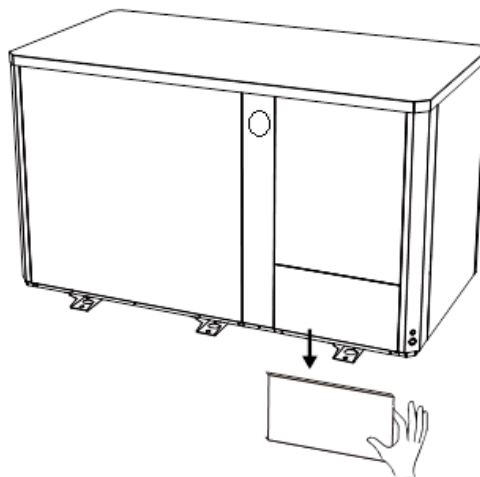

③ Remove two screws inside

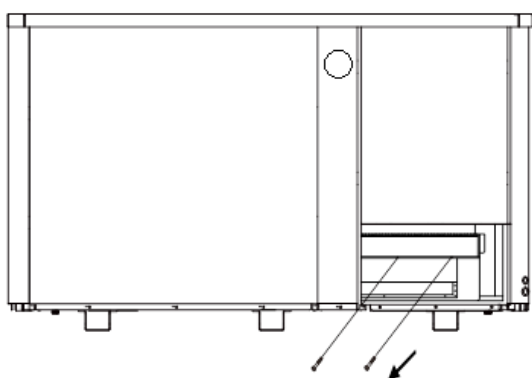

④ Open the internal

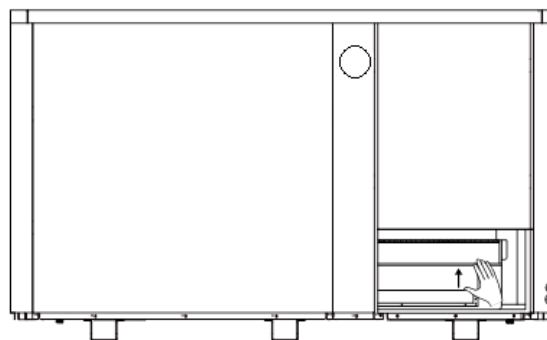

Step 2. Power cord must be passed through below 3 holes

① Connect the wire through three holes

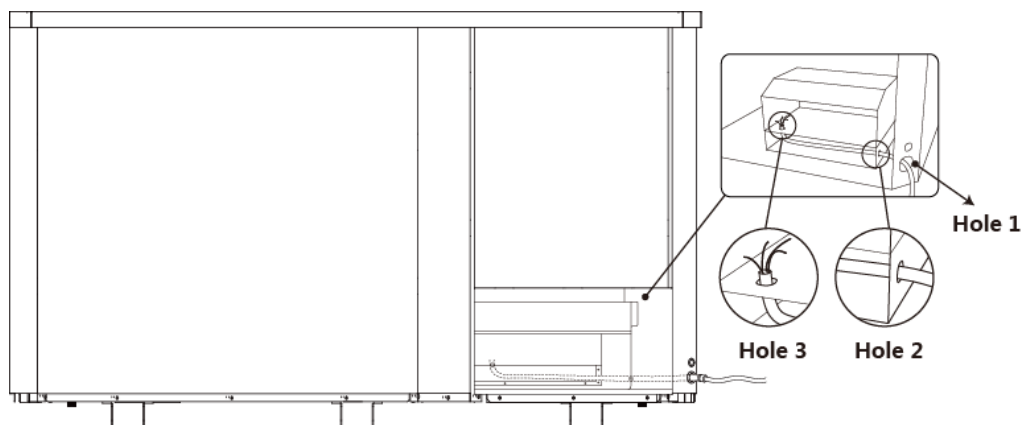

② Restore the internal panel

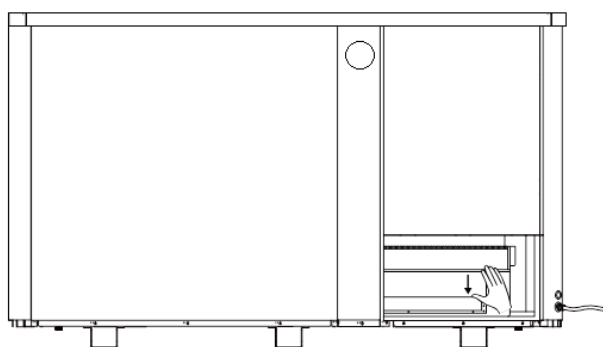

③ Fix the internal panel by two screws

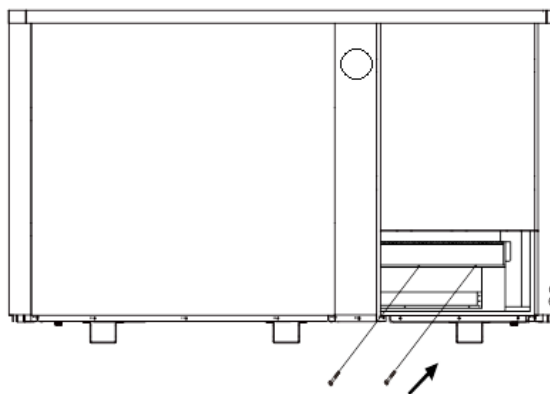

④ Restore the panel

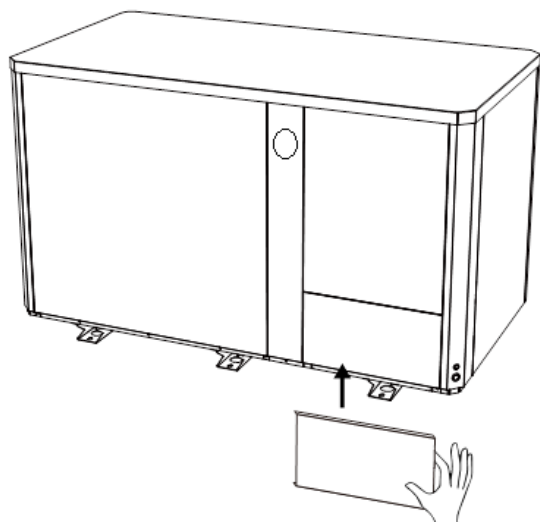

⑤ Fix the panel by three screws

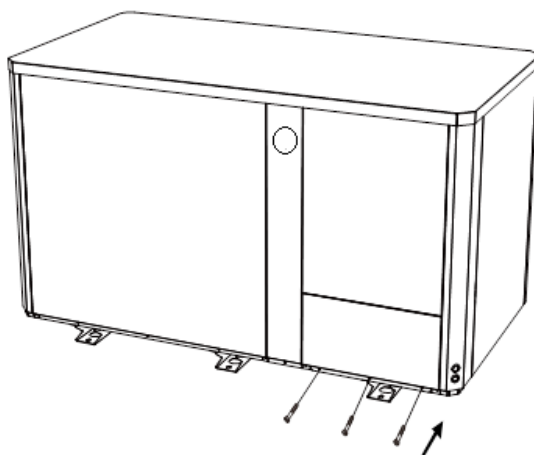



2. Wiring

- a. Connect to appropriate power supply, the voltage should comply with the rated voltage of the products.
- b. Earth the machine well.
- c. Wiring must be handled by a professional technician according to the circuit diagram.
- d. Set leakage protector according to the local code for wiring (leakage operating current $\leq 30\text{mA}$).
- e. The layout of power cable and signal cable should be orderly and not affecting each other.

3. Electric wiring Diagram

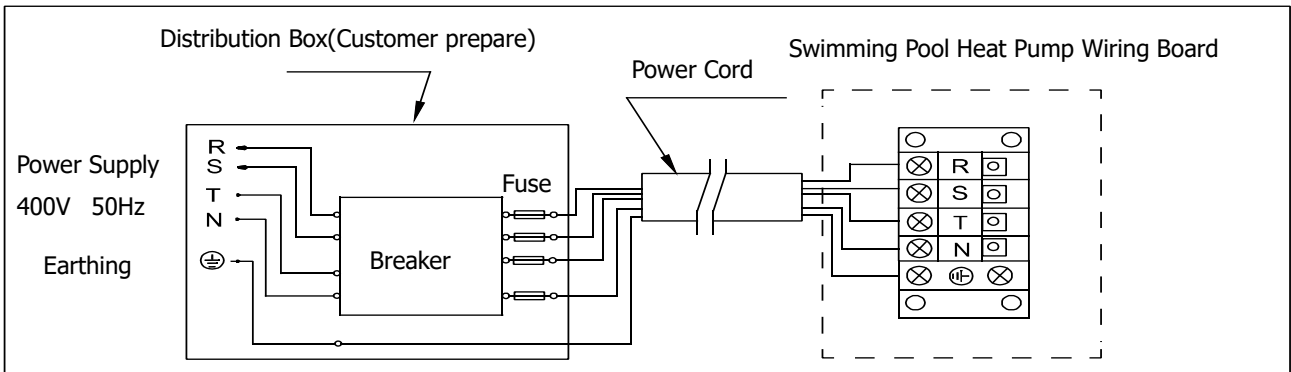
For power supply: **400V 50Hz**



- Note: 1)  Must be hard wired, plug is not allowed.
 2) The swimming pool heat pump must be earthed well.

4. References for protecting devices and cable specification

MODEL		IM60	IM110
Breaker	Maximum Current (A)	25	48
	residual-current circuit breaker (A)	30	30
Fuse (A)		25	48
Power Cord (mm ²)		5×6	5×16
Signal cable (mm ²)		3×0.5	3×0.5

※ Above data is subject to modification without notice.

Note: The above data is adapted to power cord $\leq 10\text{m}$. If power cord is $> 10\text{m}$, wire diameter must be increased. The signal cable can be extended to 50m maximumly.

E. Operation guidance

1. Key Function



Symbol	Heating & cooling models
	i. Power On/Off ii. Wi-Fi setting
	i. Lock/Unlock Screen ii. Heating mode (18-40°C) iii. Cooling mode (12-30°C) iv. Auto mode (12-40°C)
	i. Boost ii. Silence
	Temperature Setting

Attention:

- i. The controller has power-down memory function.
- ii. The buttons will turn dark when it's locked.

2. Operation Instruction

a. Screen Lock

- 1) Press for 3 seconds to lock or unlock the screen
- 2) Automatic Lock Period: 30 seconds if no operation

b. Power On

Press for 3 seconds to unlock screen, Press to power on machine.

c. Temperature Setting

Press  and  to display and adjust set temperature.

d. Mode Selection

1) Heating/Cooling/Auto

Press "" to switch among heating "", cooling "" and auto mode "".

Heating mode ">: Water temperature setting range(18-40°C)



Cooling mode ">: Water temperature setting range(12~30°C)

Auto mode ">: Water temperature setting range(12~40°C)

* When water inlet temperature is higher than setting point, automatic cooling mode starts.

* When water inlet temperature is lower than setting point, automatic heating mode starts.

2) Silence/Boost mode selection

Press "" to switch among boost mode , silence mode 

Default mode: boost 

Please choose boost mode  for initial heating





e. WIFI

When the screen is on, press "" for 3 seconds, after "" flashing, enter Wi-Fi connection.

Connect Wi-Fi on mobile phone and input password, and then control equipment by Wi-Fi. When APP connects Wi-Fi successfully, "" lights on.

f. Defrosting

1) Automatic defrosting: When machine is auto defrosting,  will flash, and return to previous working mode when it finishes.

2) Manual Defrosting: To enter forced defrosting mode, the compressor must be working more than 10 minutes. in heating mode, press "" and "" on touch controller simultaneously for 5 seconds to start forced defrosting, "" is flashing and defrost starts, "" stop flashing and defrosting stops. (Remarks: the interval between manual defrosting should be more than 30 minutes.)

F. Testing

1. Inspect heat pump before use

-
- b. The ventilating device and outlets are operating adequately and are not obstructed.
 - c. It's prohibited to install refrigeration pipe or components in corrosive environment.
 - d. Inspect the electric wiring on basis of the electric wiring diagram and earthing connection.
 - e. Double confirm the main machine power switch should be off.
 - f. Inspect the air inlet and outlet.

2. Trial

- a. The user must “Start the Pump before the Machine, and Turn off the Machine before the Pump”, or the machine will be damaged.
- b. Before start the heat pump, please check for any leakage of water.
- c. In order to protect the swimming pool heat pump, the machine is equipped with a time lag starting function, the fan will run 1 minute earlier than the compressor when starting the machine, and it will stop running 1 minute later than the compressor when power off the machine.
- d. After the swimming pool heat pump start up, please kindly checking for any abnormal noise from the machine.

G. Maintenance



**“CUT OFF” power supply of the heater
before cleaning, examination and repairing**

- 1. In winter season when you don't swim:
 - a. Cut off power supply to prevent any machine damage.
 - b. Drain water clear of the machine.
 - c. Cover the machine body when not in use.



!!Important:

Unscrew the water nozzle of inlet pipe to let the water flow out.

When the water in machine freezes in winter season, the titanium heat exchanger may be damaged.

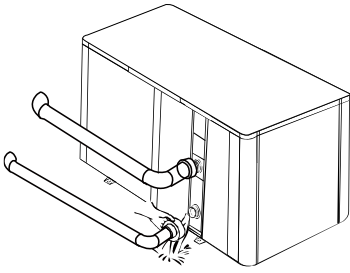

2. Please clean this machine with household detergents or clean water, NEVER use gasoline, thinners or any similar fuel.
3. Check bolts, cables and connections regularly.
4. If repair or scrap is required, please contact authorized service center nearby.
5. Do not attempt to work on the equipment by yourself. Improper operation may cause danger.

H. Trouble shooting for common faults

1. Failure solution and code

Failure	Reason	Solution
Heat pump doesn't run	No power	Wait until the power recovers
	Power switch is off	Switch on the power
	Fuse burned	Check and change the fuse
	The breaker is off	Check and turn on the breaker
Fan running but with insufficient heating	evaporator blocked	Remove the obstacles
	Air outlet blocked	Remove the obstacles
	3 minutes start delay	Wait patiently
Display normal, but no heating	Set temp. too low	Set proper heating temp.
	3 minutes start delay	Wait patiently
If above solutions don't work, please contact your installer with detailed information and your model number. Don't try to repair it yourself.		

Note: If the following conditions happen, please stop the machine immediately, and cut off the power supply immediately, then contact your dealer:

1. Inaccurate switch action.
2. The fuse is frequently broken or leakage circuit breaker jumped.

Protection & Failure code

NO.	Display	Protection code description
1	E3	No water protection
2	E5	Power supply excesses operation range
3	E6	Excessive temp difference between inlet and outlet water(Insufficient water flow protection)
4	Eb	Ambient temperature too high or too low protection
5	Ed	Anti-freezing reminder
NO.	Display	Failure code description
1	E1	High pressure protection
2	E2	Low pressure protection
3	E4	3 phase sequence protection (three phase only)
4	E7	Water outlet temp too high or too low protection
5	E8	High exhaust temp protection
6	EA	Evaporator overheat protection (only at cooling mode)
7	EC	System communication failure
8	P0	Controller communication failure
9	P1	Water inlet temp sensor failure
10	P2	Water outlet temp sensor failure
11	P3	Gas exhaust temp sensor failure
12	P4	Evaporator coil pipe temp sensor failure
13	P5	Gas return temp sensor failure
14	P6	Cooling coil pipe temp sensor failure
15	P7	Ambient temp sensor failure
16	P8	Cooling plate sensor failure
17	P9	Current sensor failure
18	PA	Restart memory failure
19	F1	Compressor drive module failure
20	F2	PFC module failure
21	F3	Compressor start failure
22	F4	Compressor running failure
23	F5	Inverter board over current protection
24	F6	Inverter board overheat protection
25	F7	Current protection
26	F8	Cooling plate overheat protection
27	F9	Fan motor failure
28	Fb	Power filter plate No-power protection
28	FA	PFC module over current protection
29	FA	PFC module over current protection
30	FC	AC fan motor overcurrent protection
31	Fd	AC fan motor overheat protection
32	FE	AC fan motor phase protection

I. Electrical wiring schematic (optional)

Water pump: 400V voltage

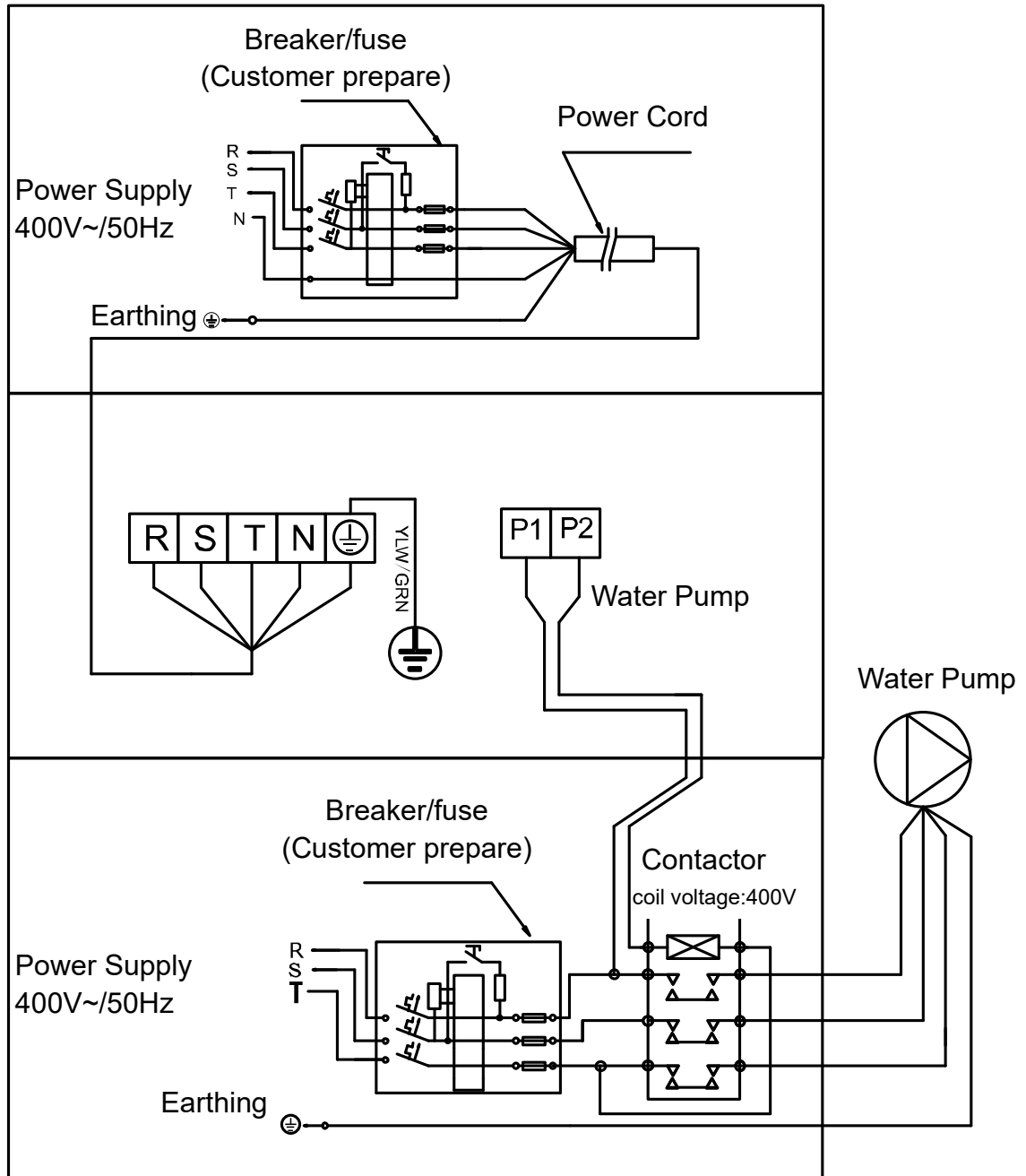

Water pump control and timer connection

1: Water pump timer

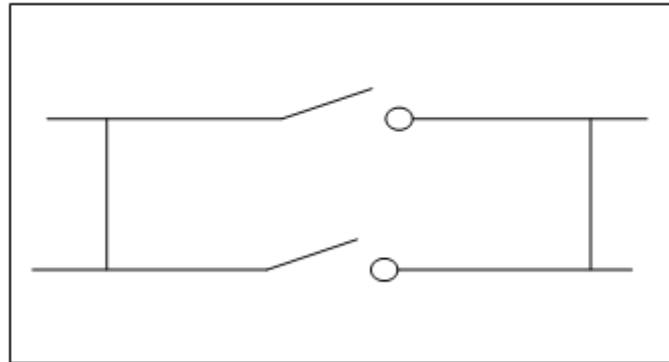

2: Water pump wiring of Heat Pump

Note: The installer should connect 1 parallel with 2 (as above picture). To start the water pump, condition 1 or 2 is connected. To stop the water pump, both 1 and 2 should be disconnected.

J. Wi-Fi operation

1 APP Download



Android please download from



iPhone please download from



2 Account Registration

1. Register by mobile or email



2. Create your password

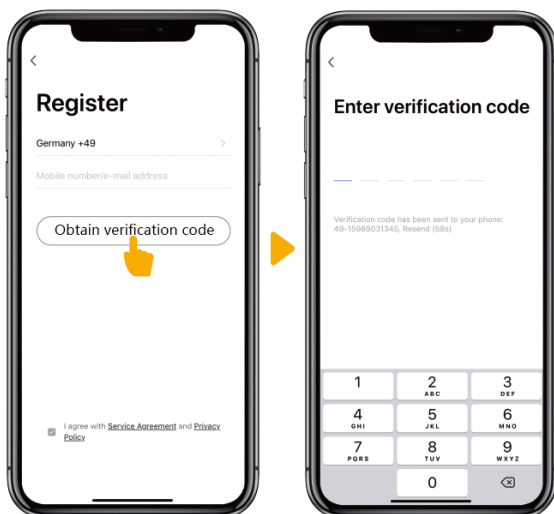

3 APP Binding

Please make sure you are connected to the Wi-Fi.

Press "Ⓜ" for 3 seconds to unlock the screen, press "⓪" for 3 seconds then release, after hearing "Beep".

Enter Wi-Fi code. During connection, "📶" flashes. When the APP connects to the Wi-Fi successfully, the "📶" will display



Click "Add device", and then follow instructions to pair device.

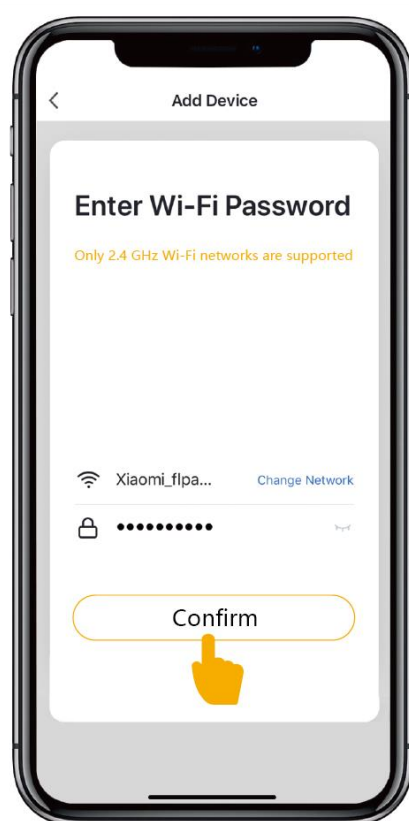
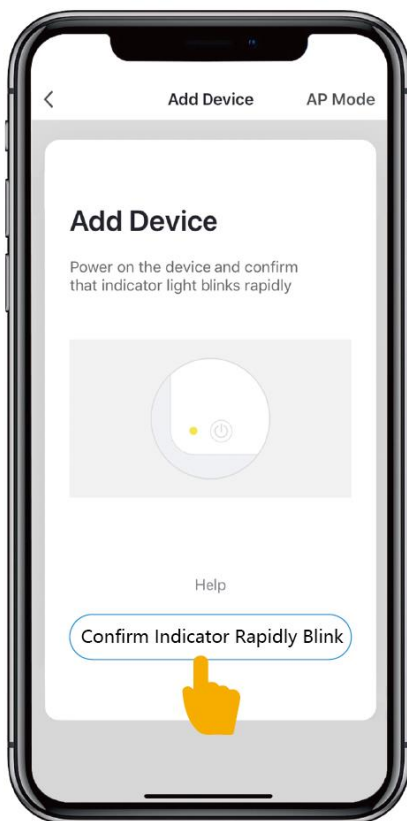
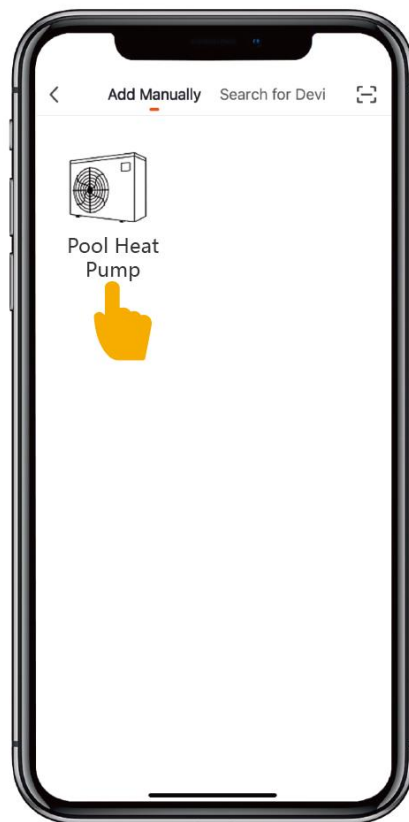
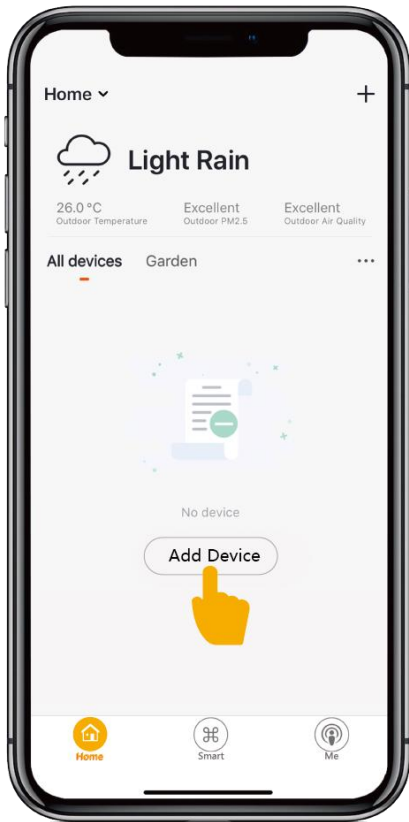

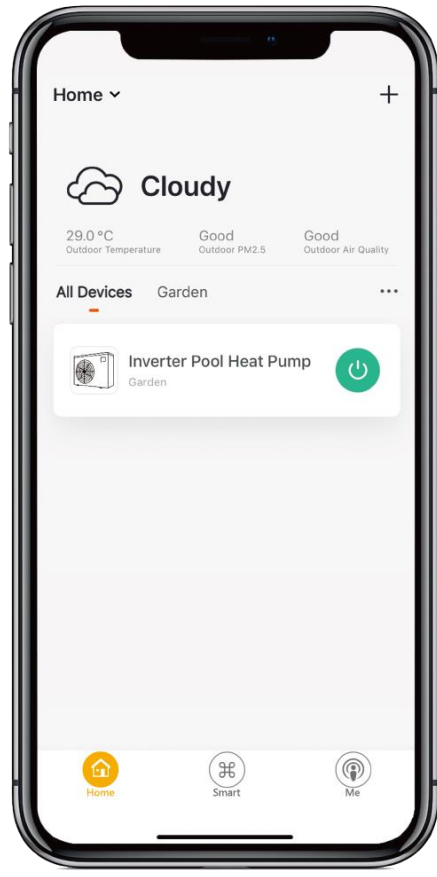
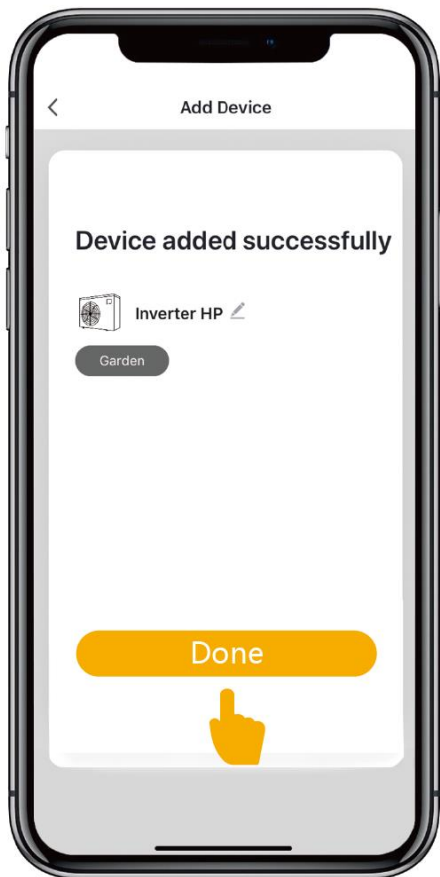
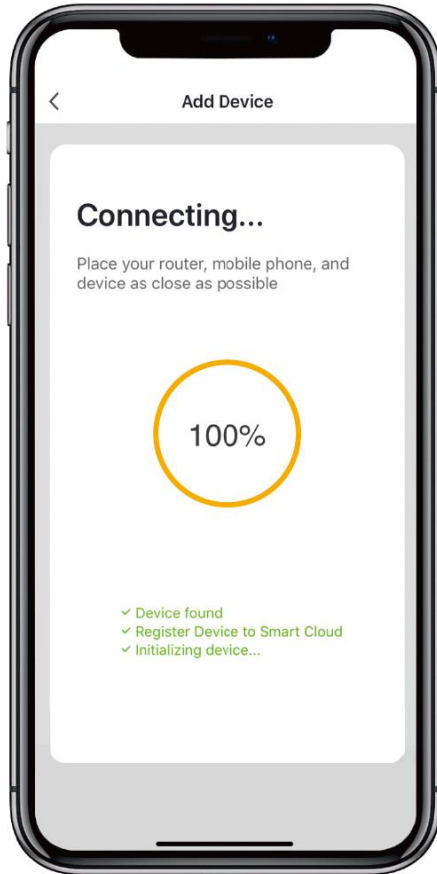
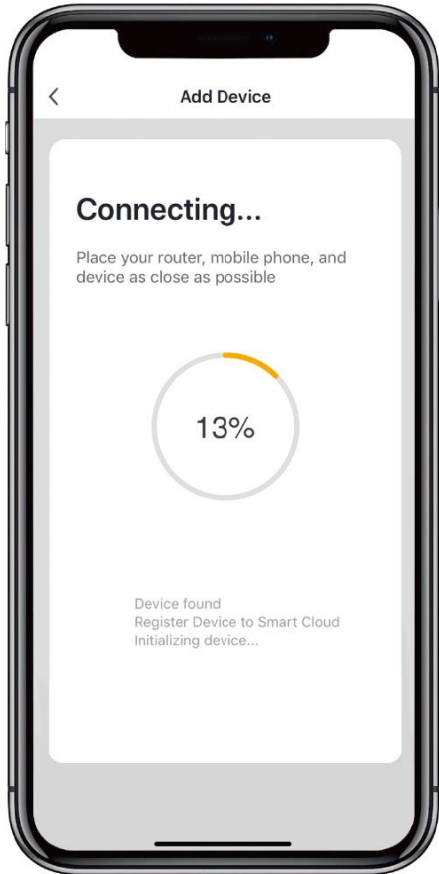

4 Operation

For heat pump with Heating & Cooling function :



Notice:

- 1.The weather forecast is just for reference.
- 2.APP is subject to updating without notice.